

QUICK-COUPLING MAGNET DIESEL ENGINE FIXED REEVED

TYPE D-RLB

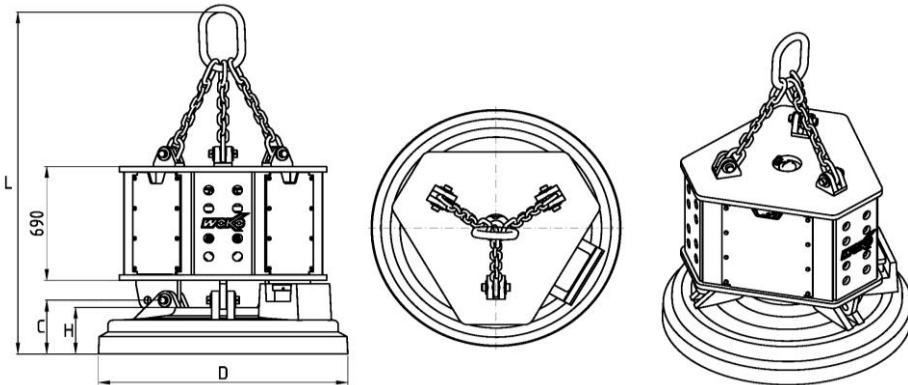

MAGNET type	DIAMETER (mm)	WEIGHT (kg)	POWER* (kW)	PULL-OFF STRENGTH** (kN)	SLAB / INGOT (kg)	LIFTING CAPACITY***			
						PIG IRON (kg)	CAST IRON SCRAP (kg)	SOLID SCRAP (kg)	SHORT CHIPS (kg)
D-RLB-GS 10	1.000	1.425	5,9	210	9.900	490	450	400	200
D-RLB-GS 12	1.200	2.020	8,6	290	15.100	880	675	610	355
D-RLB 10	1.000	1.480	4,8	190	9.500	480	420	370	190
D-RLB 11.5	1.150	1.810	5,5	240	12.000	660	530	490	260
D-RLB 12.5	1.250	2.060	8,8	280	14.000	850	650	580	340

COMMENT:

1. Nominal operating voltage is 220V/DC. The indicated power consumption is according to the cold amperage draw of the magnet, important for proper selection of the electrical equipment. As a result of heating up of the magnet coil, power consumption will decrease while working with the magnet.
2. Indicated pull-off strength is in accordance to German standard DIN EN 13155 and refers to a flat solid thick steelplate (slab), on an air-gap of 1/300 of the magnet diameter "D".
3. Indicated lifting capacities based on tests under optimum conditions in accordance to German standard DIN EN 13155; actual performance will vary with specific operating conditions.

Data subject to change without notice. All rights reserved.

Copyright © 2015 WOKO Magnet- und Anlagenbau GmbH